

SWINGING 500

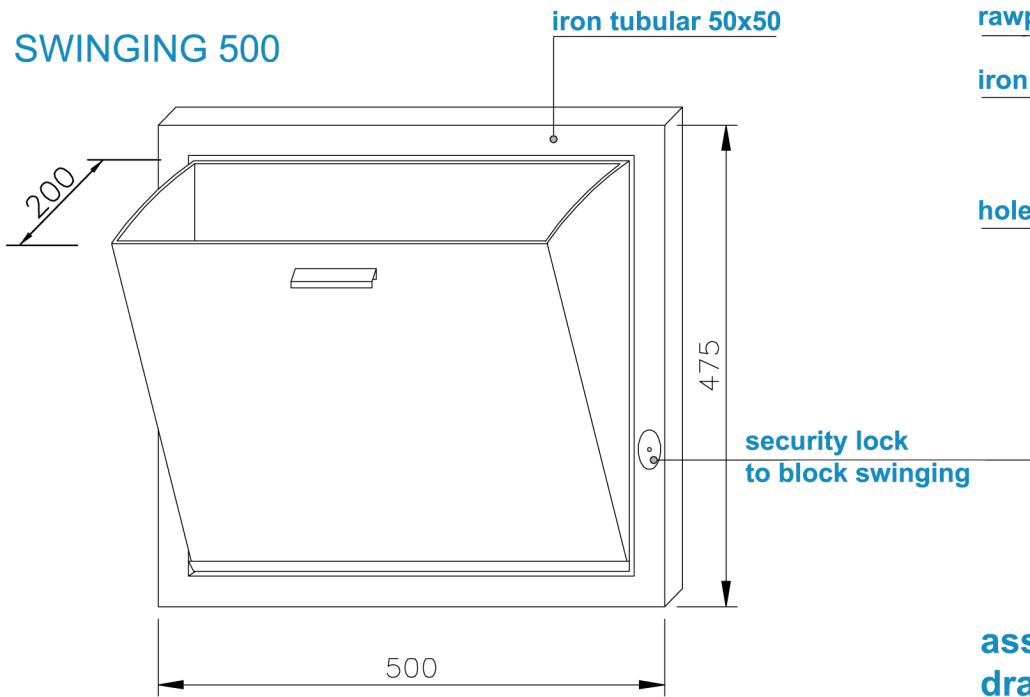

rawplug 80x100

iron tubular 50x50

hole 14/8

assembly drawing

SWINGING 300

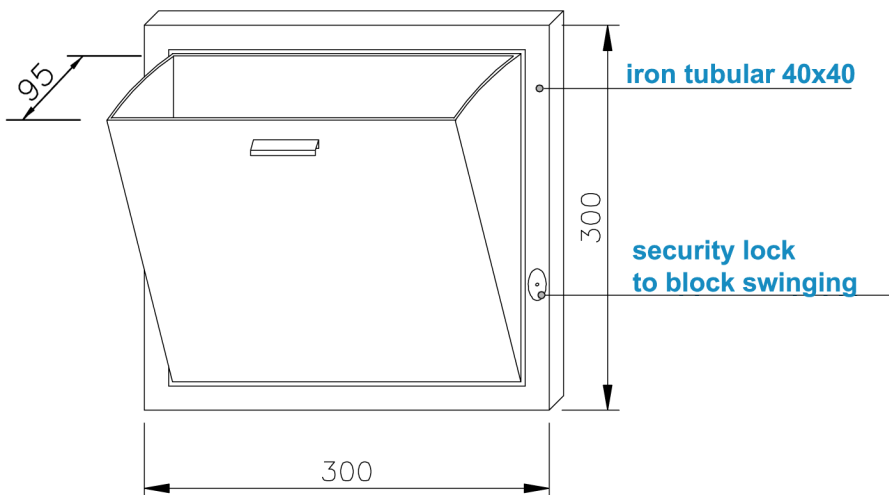

The model "SWINGING" exchange container has bulletproof specifications and is manufactured with steel sheet 30/10 mm (5/32 inches) thick, it is used to exchange items and small objects through separated work spaces and is mounted on a bulletproof structure. The container includes a security lock to ensure unauthorized usage.

See the technical file to know features and measures.

Available upon request: armoring increased or ballistics and different design.